

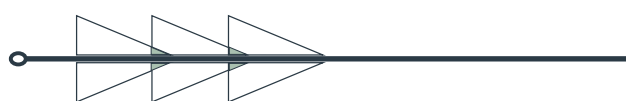

Bygget - hva det har å tilby -

Litt om bygget
Inspirasjon av andre leietagere i bygget
Plassering av ledige lokaler i bygget
Araldisponeringer

GJERDRUMS VEI 4



Gjerdrums vei 4 er et moderne, effektivt bygg med gode takhøyder, flott utsikt og store etasjeplan.

Kontorene har store glassflater med mye dagslys og flott utsyn utover Nydalen og Akerselva. Bygget har et hyggelig inngangsparti med en innbydende kantine.

Det er god parkeringsdekning i byggets garasjeanlegg, og felles garderober. Bygget er meget sentralt plassert i Nydalen, med ca 5 min. gange til Nydalen T-banestasjon, og alle servicetilbud og butikker i sentrum av Nydalen.

Lokalene vil skreddersys for ny leietager, så det er bare å ta kontakt med oss for å se hva som er mulig

BYGGET

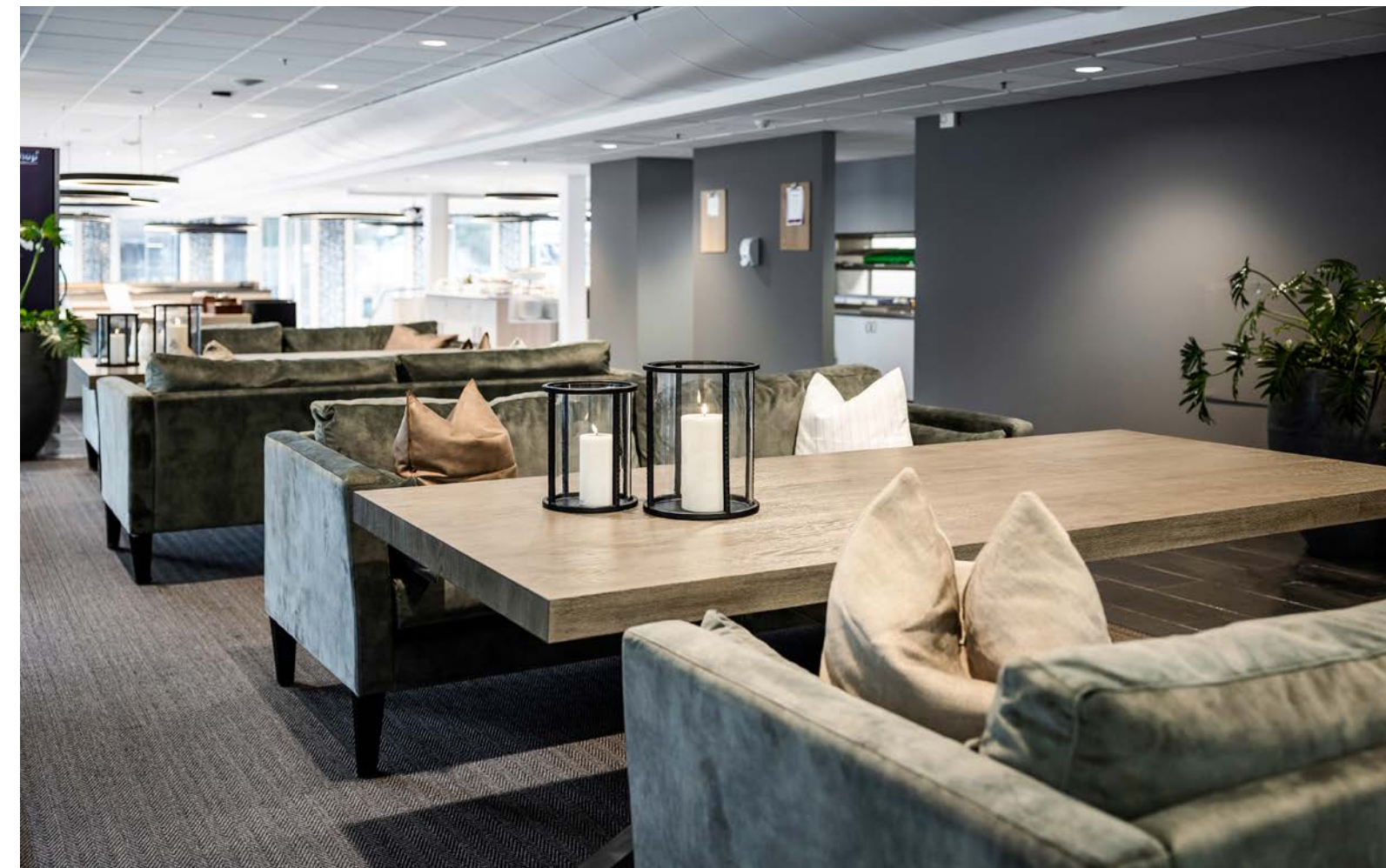

Kantine



Atriet / Lounge



Servering Lunsj

INSPIRASJON

Bilder fra annen leietagere i bygget

STEMNINGER

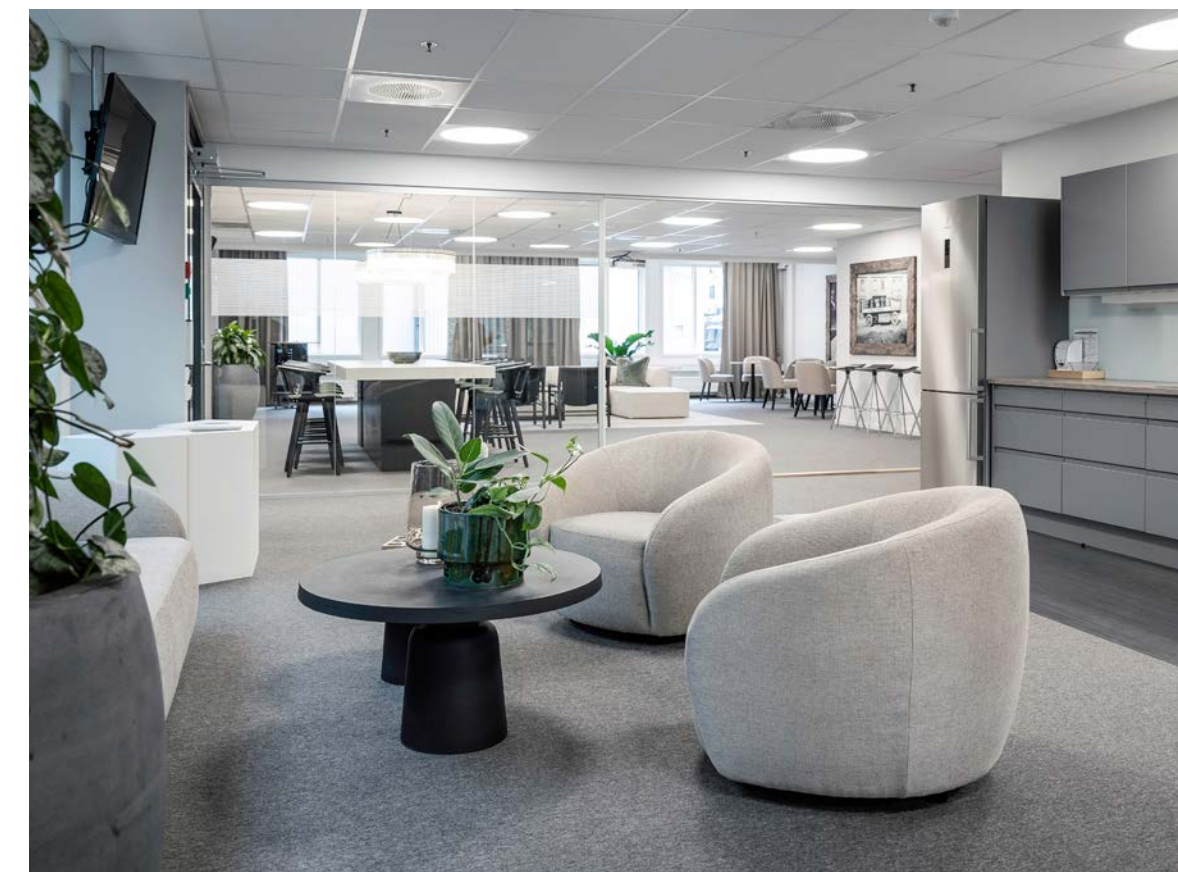
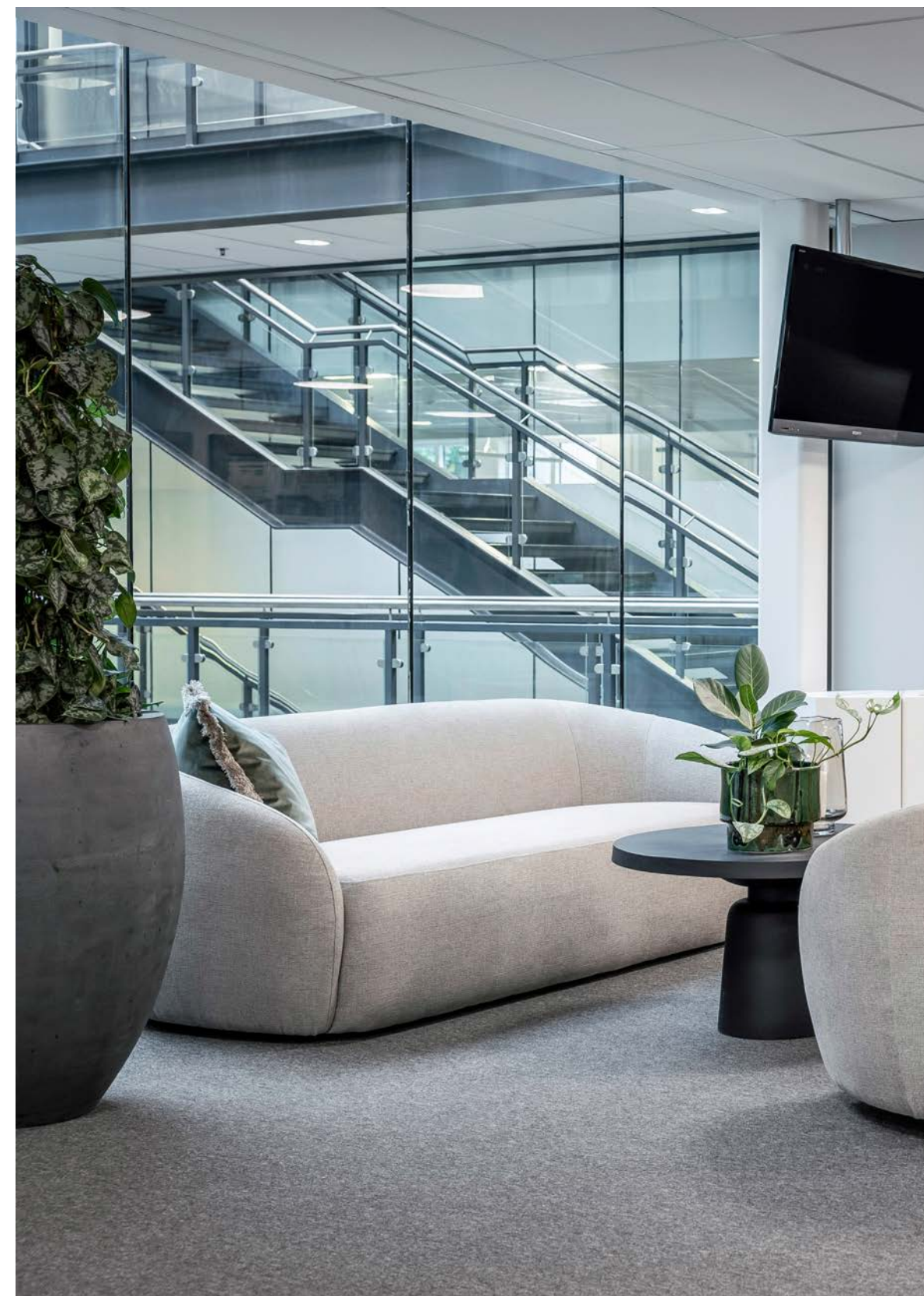

LEDIGE LOKALER I BYGGET

Det finnes ledige lokaler i 1. etasje,
2.etasje og 3.etasje. Separate leieareal

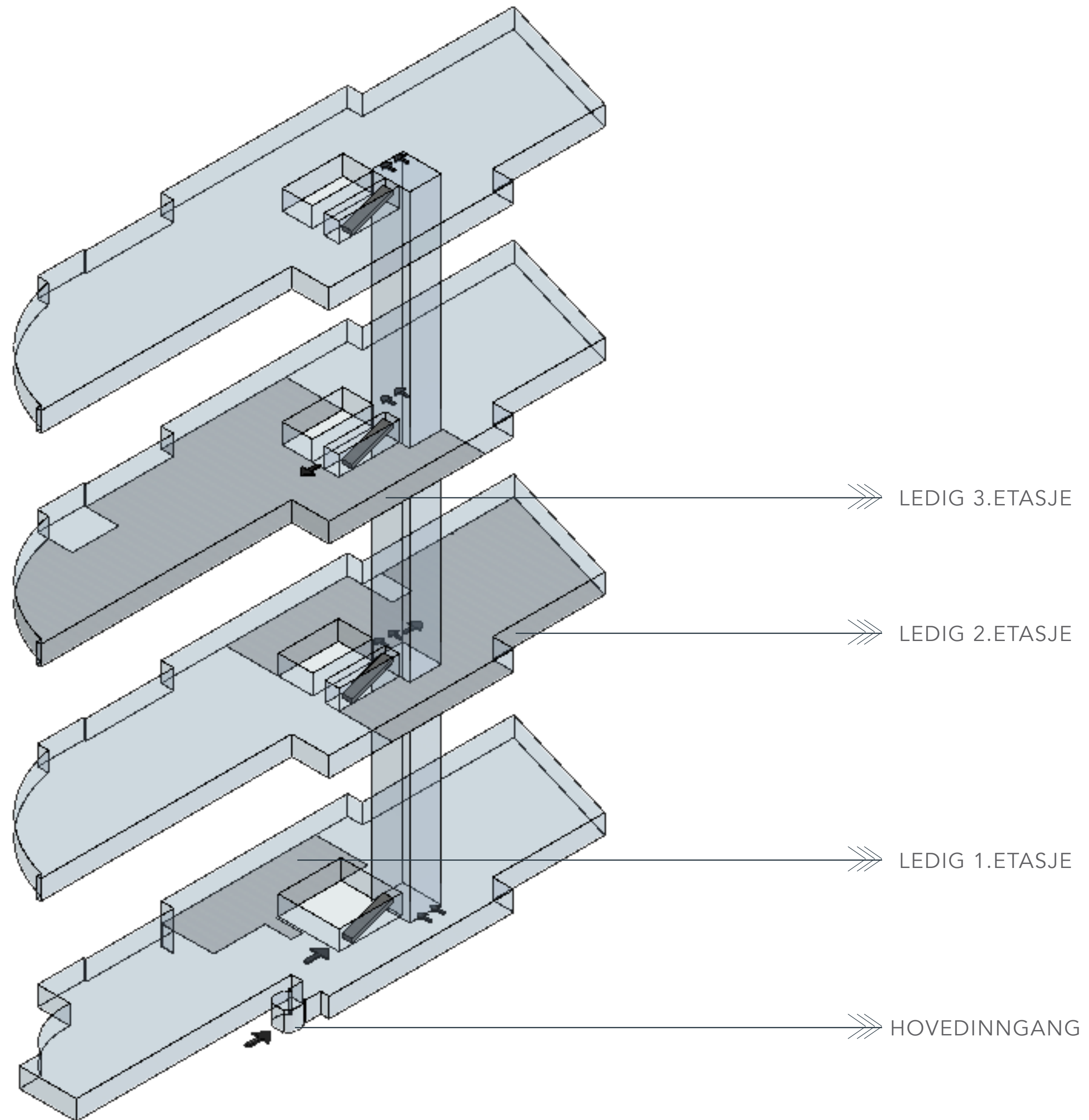

AREALDISPONERING

1. ETASJE

Fellesarealer: Inngang - kantine
lounge - toaletter

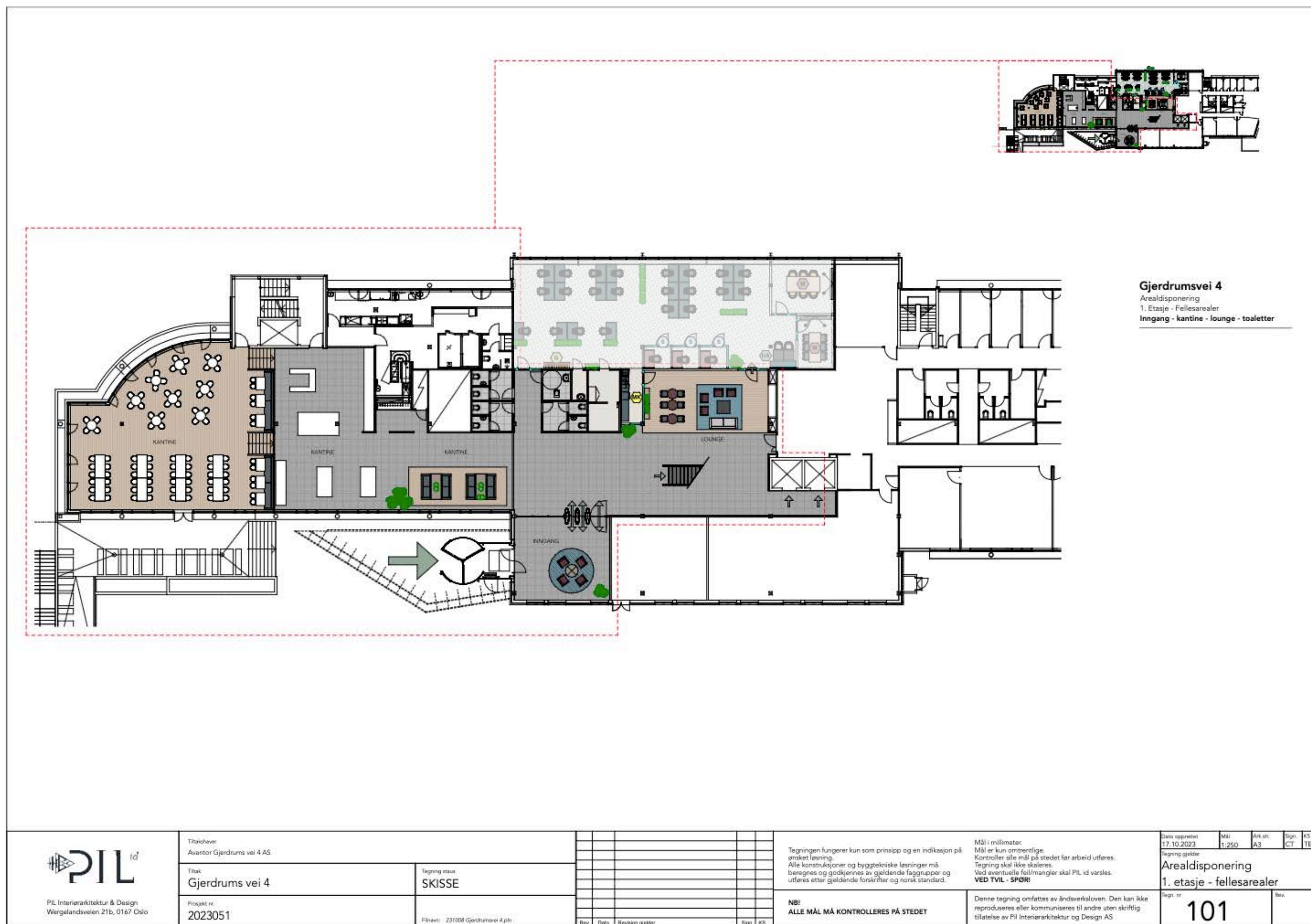
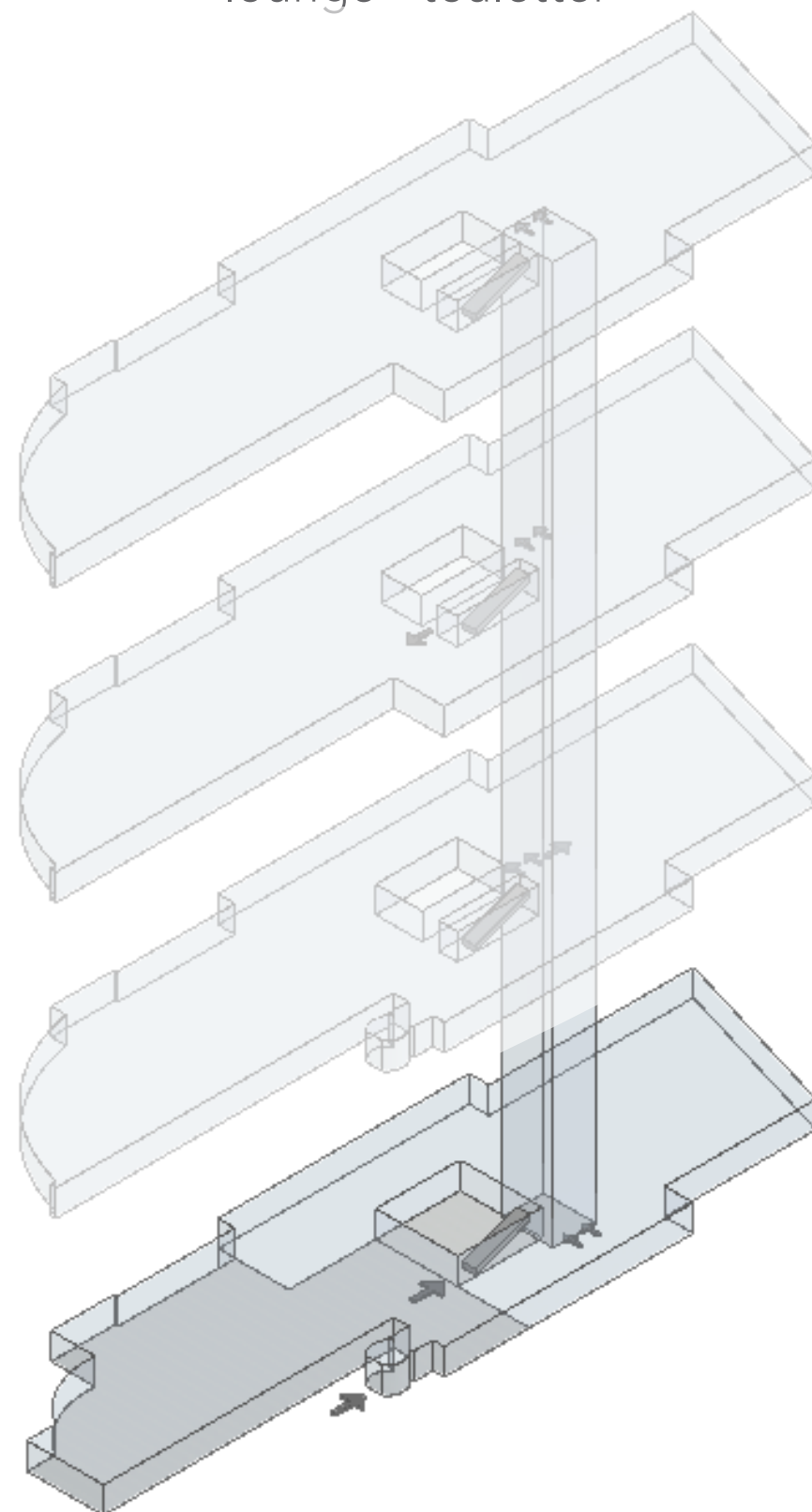

AREALDISPONERING 1. ETASJE

eget leieareal



AREALDISPONERING 2. ETASJE

eget leieareal

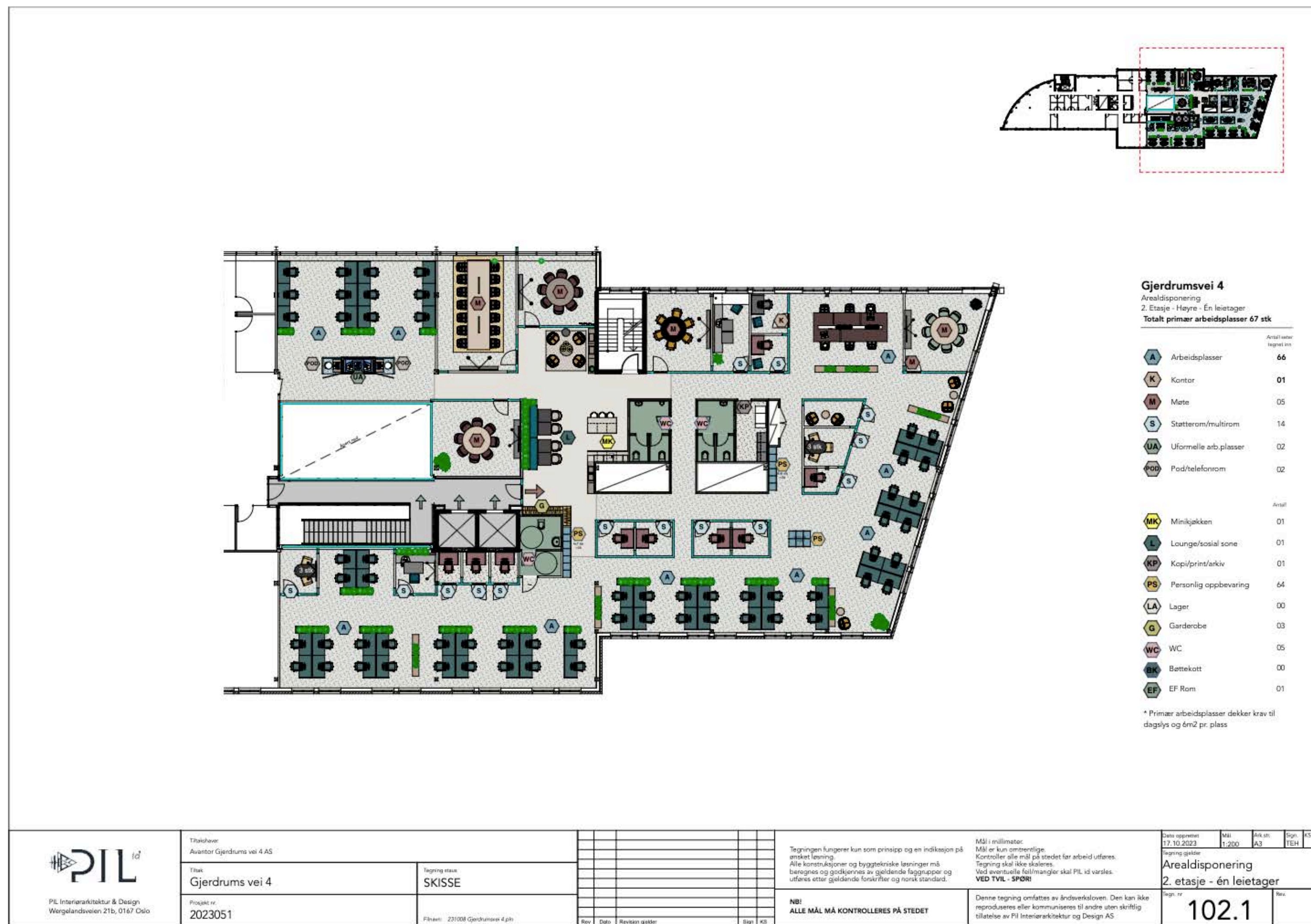
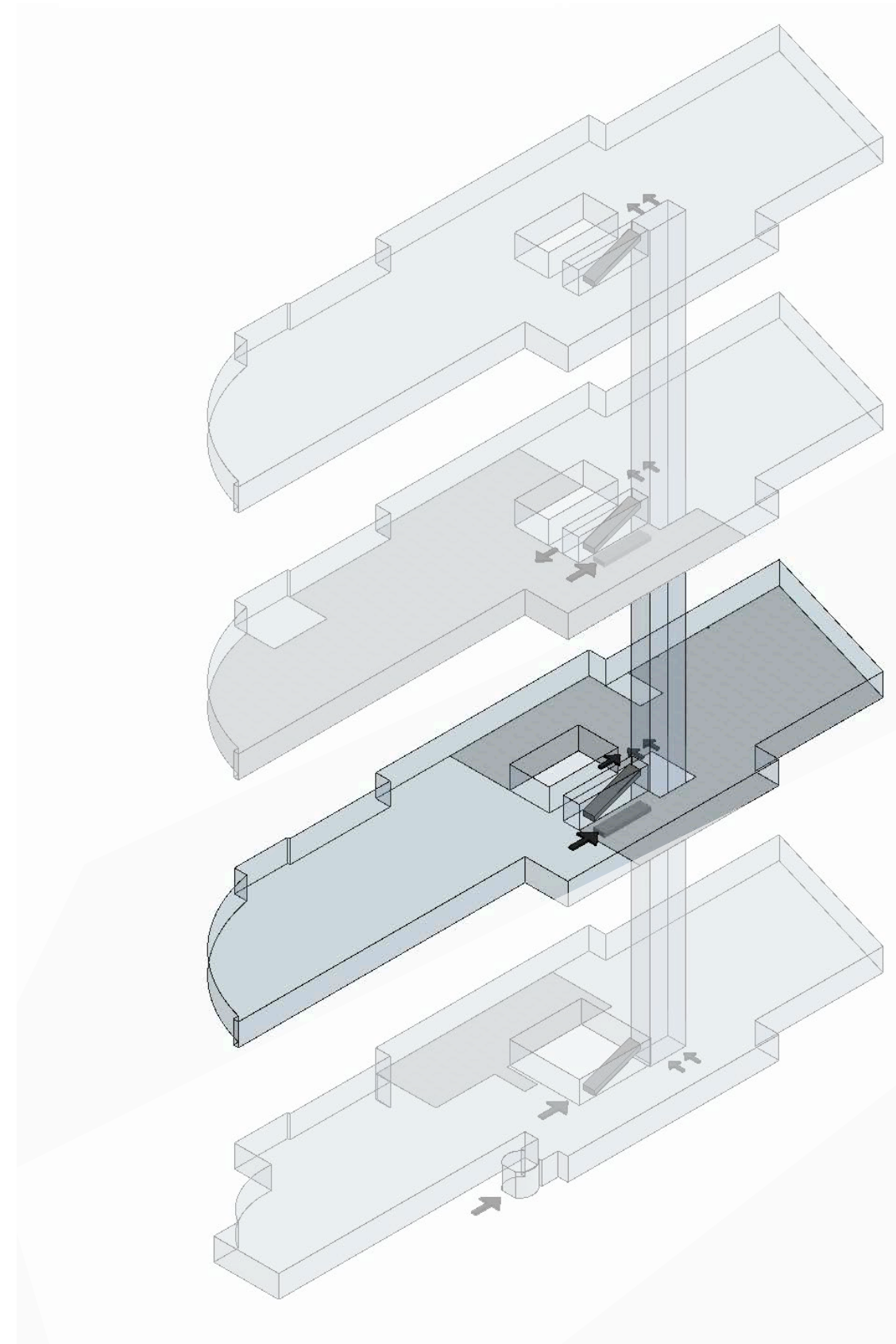

AREALDISPONERING 3. ETASJE

eget leieareal

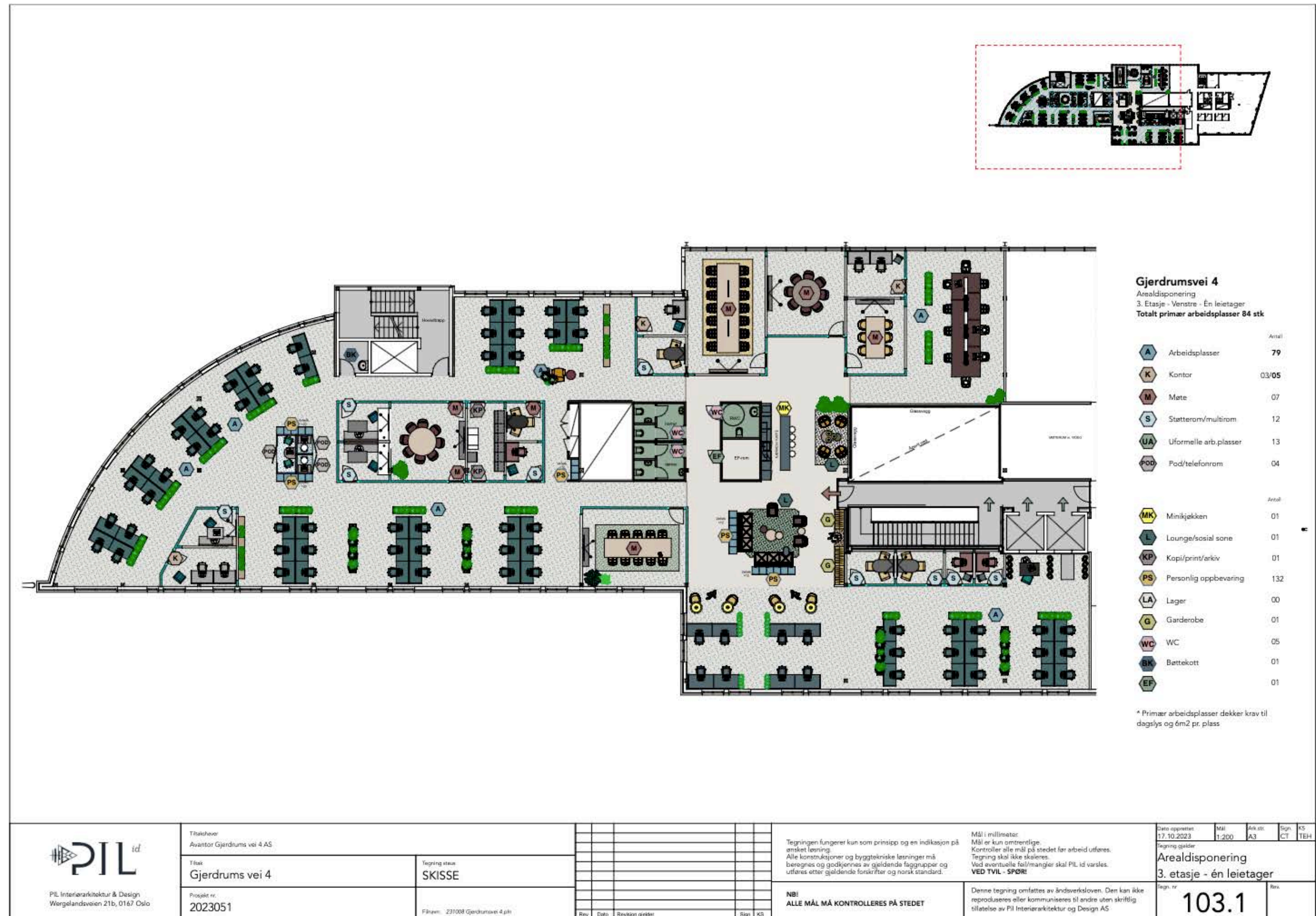
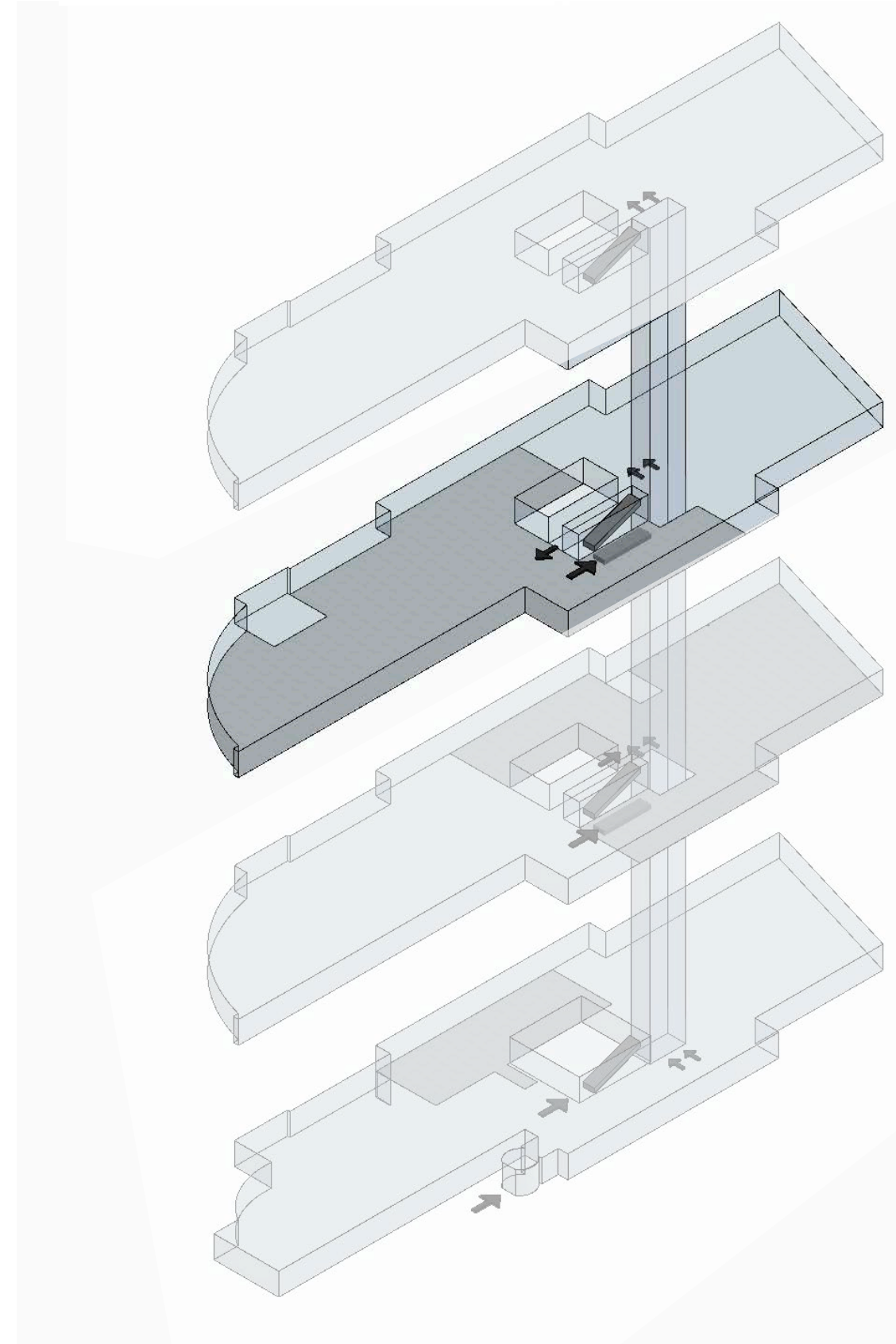

LEDIGE LOKALER I BYGGET

Lokalene i 2. etasje og 3. etasje
kan linkes sammen med intertrapp

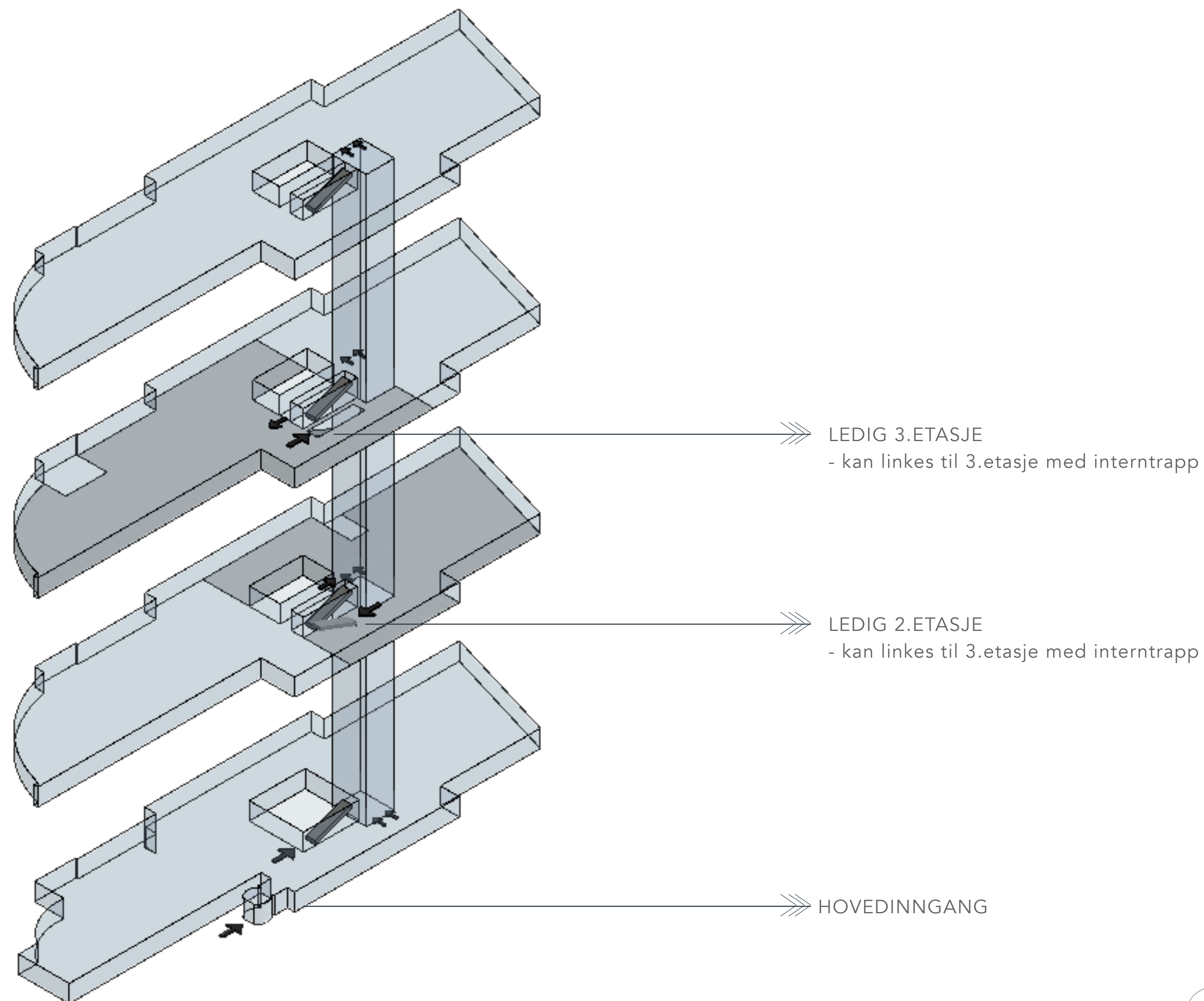

AREALDISPONERING 2. ETASJE

linket til 3. etasje med interntrepp

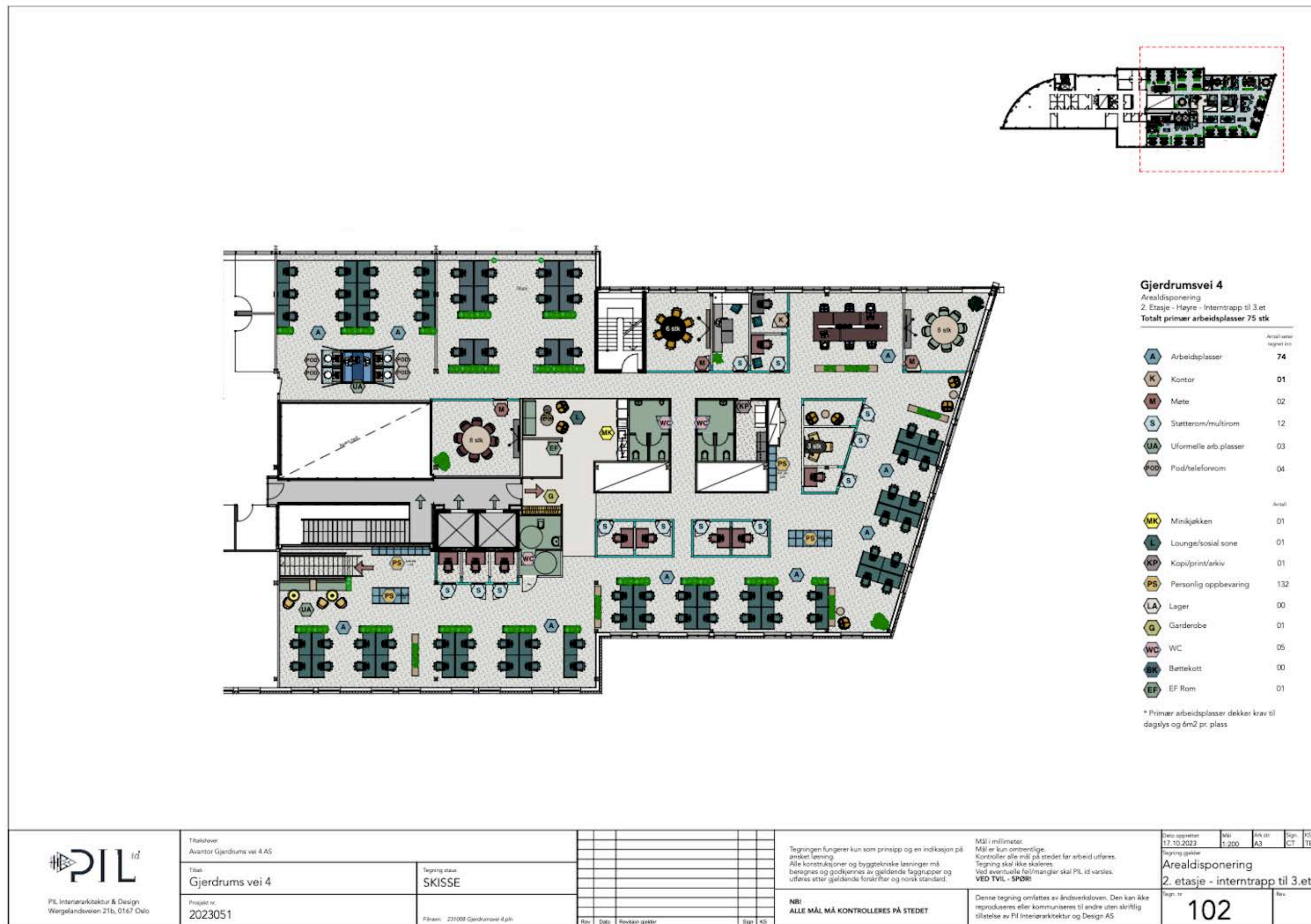
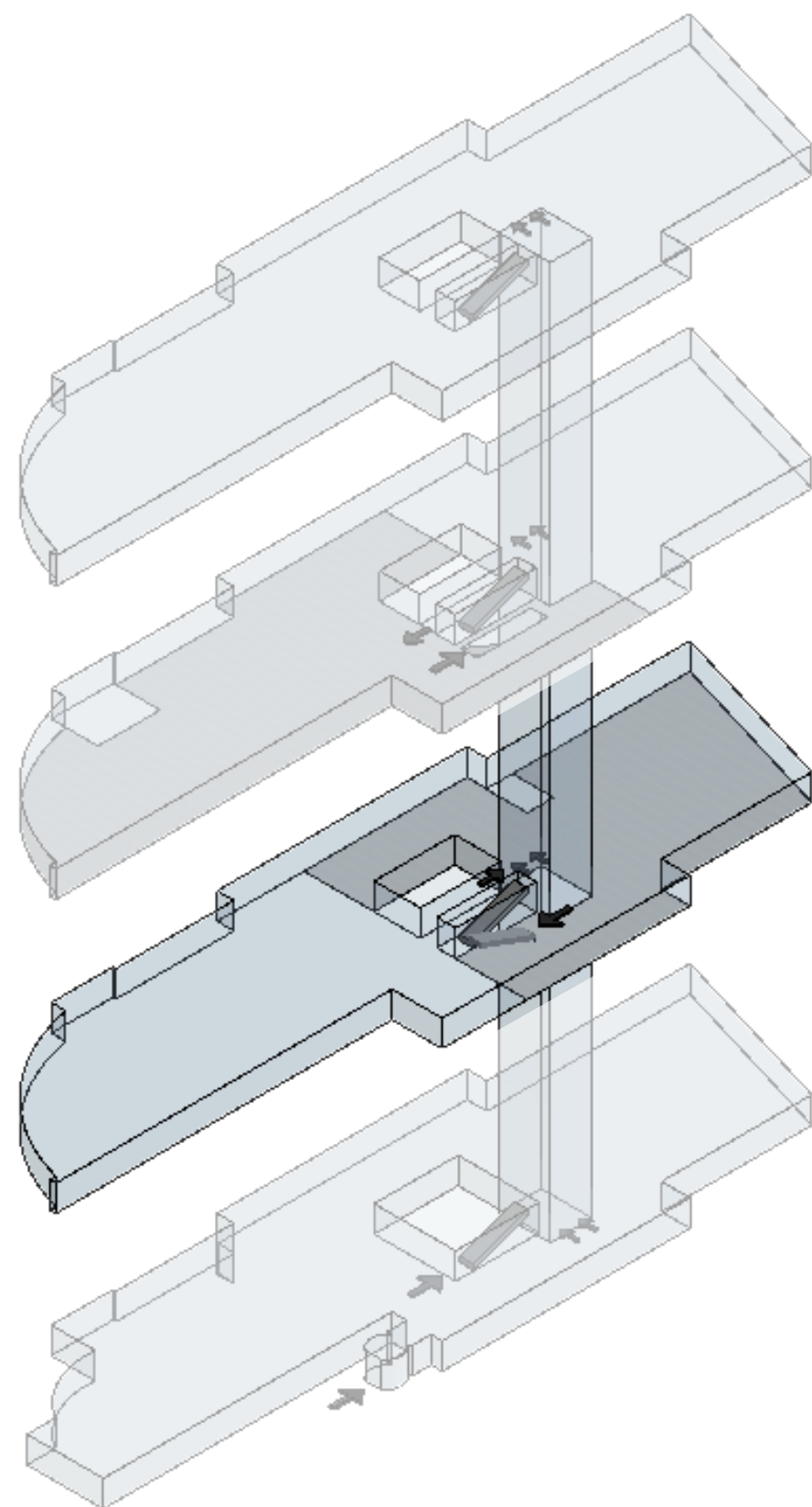

AREALDISPONERING

3. ETASJE

linket til 2. etasje med interntrepp

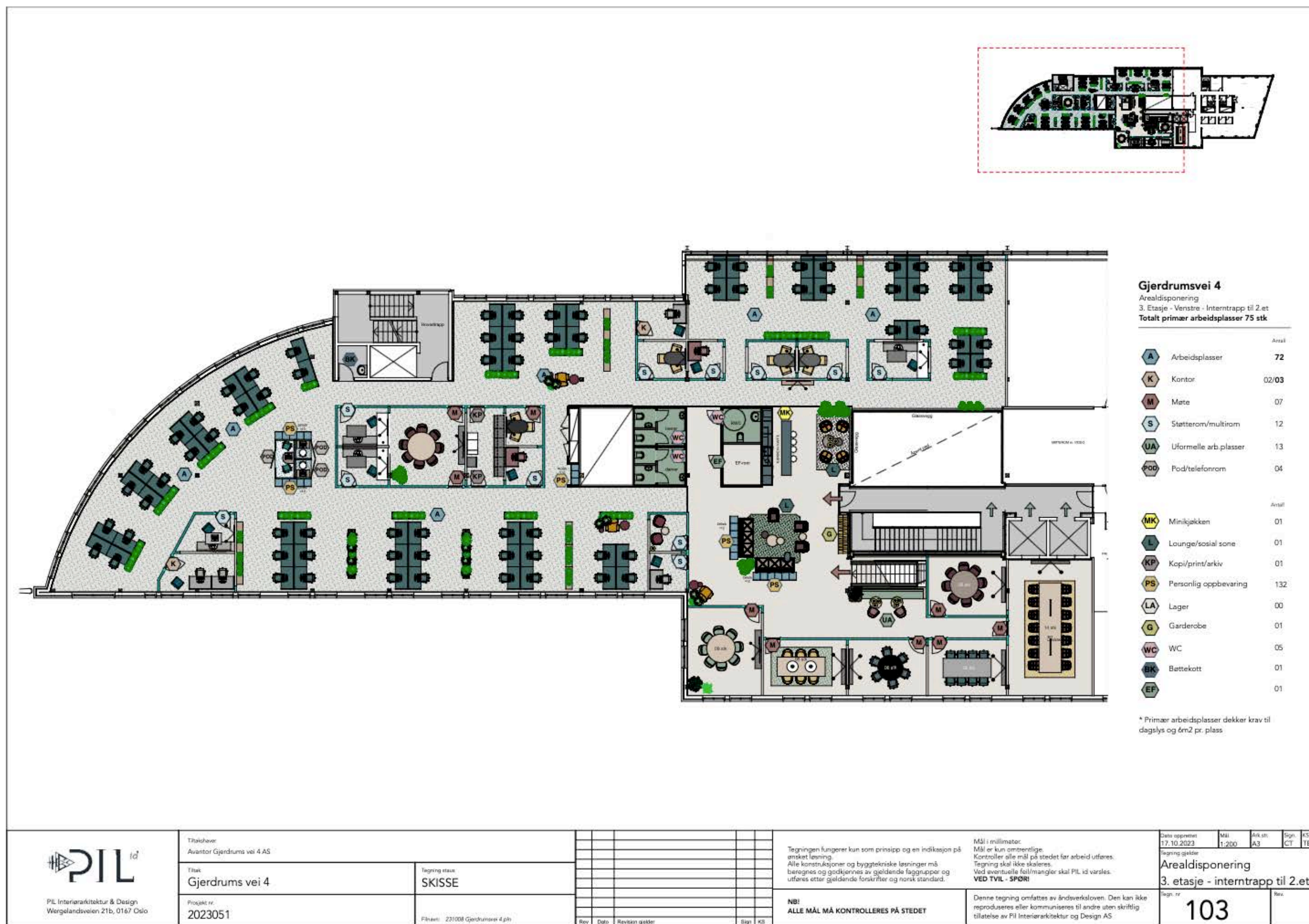
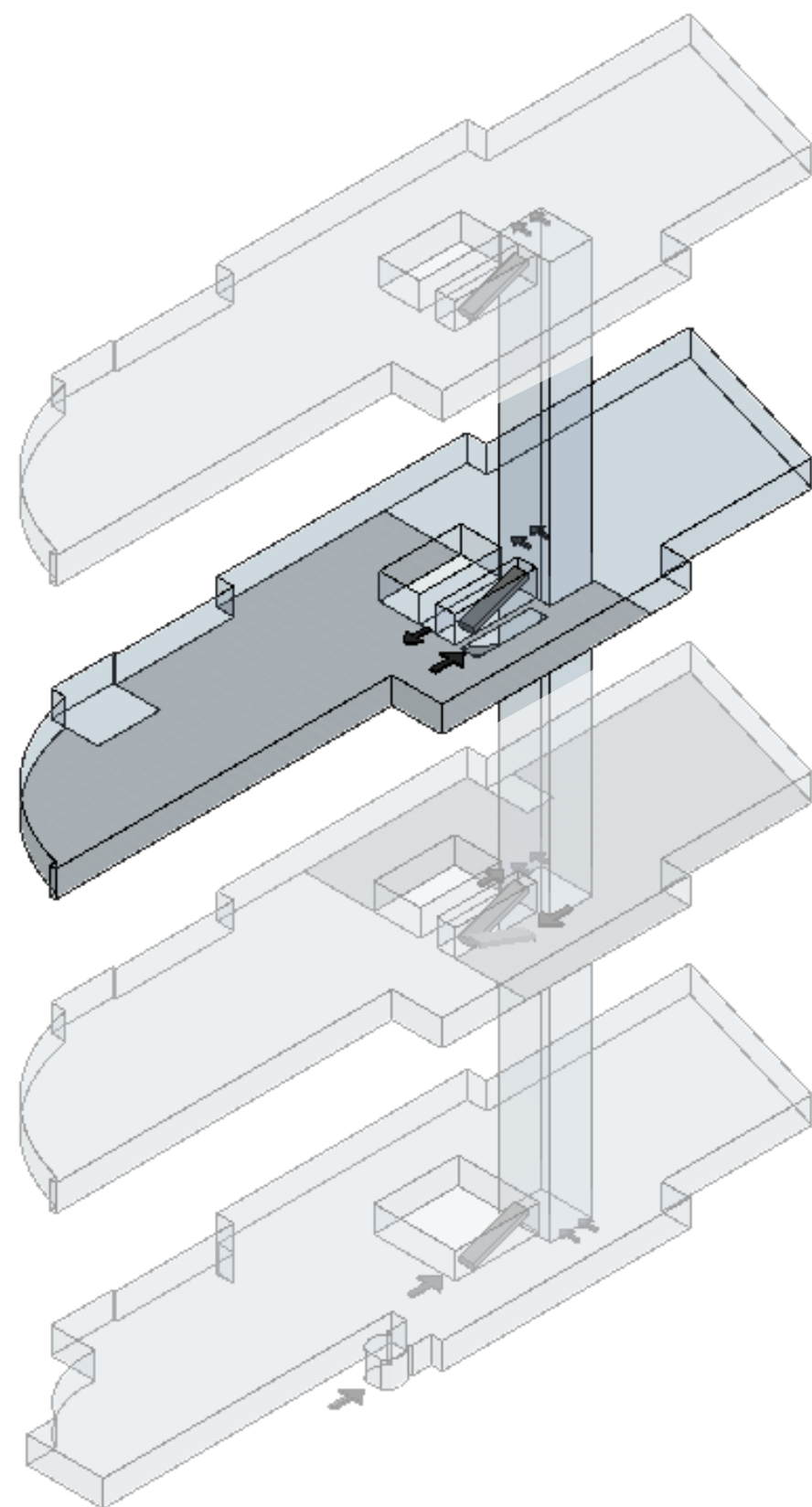



TAKK FOR OPPMERKSOMHETEN